

# RECON RETAINING WALL SYSTEM

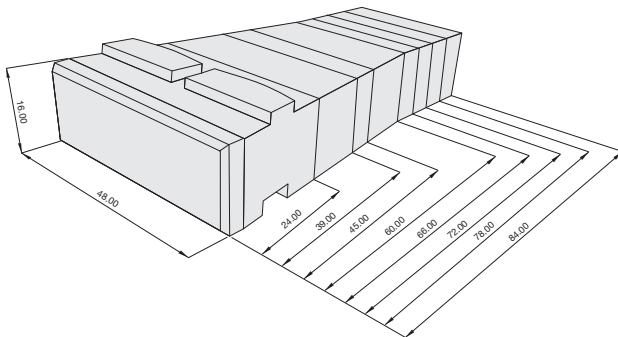

- Strong, wet cast blocks 1,457 to 4,088 lbs.
- 24" to 84" D x 48" W x 16" H
- Regular corner and cap blocks
- Half block (24" or 39" deep)
- Full fence or full high end/cap blocks
- Passed current WI DOT requirements
- Available in two unique faces
- Gray (stained after construction by a third party)

TEST	METHOD	REQUIREMENT	
		Dry-cast	Wet-cast
Compressive Strength (psi)	ASTM C140	5,000 min.	4,000 min.
Air Content (%)	AASHTO T152	N/A	6.0 +/-1.5
Water Absorption (%)	ASTM C140	6 max. <sup>[3]</sup>	N/A
Freeze-Thaw Loss (%) 40 cycles, 5 of 5 samples 50 cycles, 4 of 5 samples	ASTM C1262 <sup>[1]</sup>	1.0 max. <sup>[2][3]</sup> 1.5 max. <sup>[2][3]</sup>	N/A



Manufactured by:

7200 Broadway Ave. N, Rochester, MN 55906  
 Phone: 507-288-8850 • Fax: 507-535-1487  
[www.rochesterpc.com](http://www.rochesterpc.com)



©Copyright 2020. All Rights Reserved. This information has been prepared for the benefit of customers interested in Rochester Concrete Products. It was reviewed carefully prior to publication. Rochester Concrete Products assumes no liability for its accuracy or completeness. Final determination of the suitability of any information or material for the use contemplated, or for its manner of use, is the sole responsibility of the user. 221